

CE BREAKOUT BENCHES



The CE breakout bench range was developed to meet the demand for a safer hammer maintenance tool than what is commonly available on the market. These top quality benches tick all the right boxes to make hammer maintenance a simple exercise.

- Compact
- Self contained
- Reliable
- Safe

Multiple attachment options enables customization to suite your environment or preferences. These units include hydraulic power pack, tool storage area and safety cage all within the base dimensions preventing floor clutter such as loose spanners or hosing.

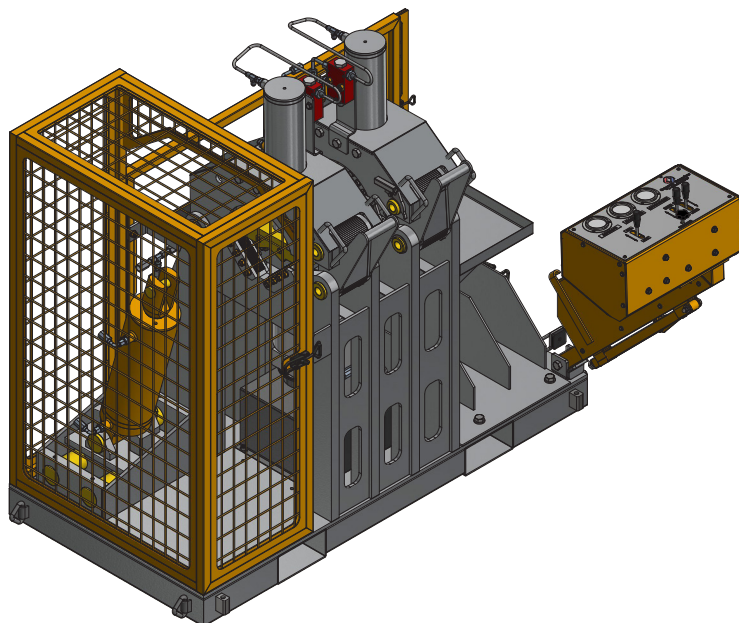

4-8 BREAKOUT BENCH - M2914-62

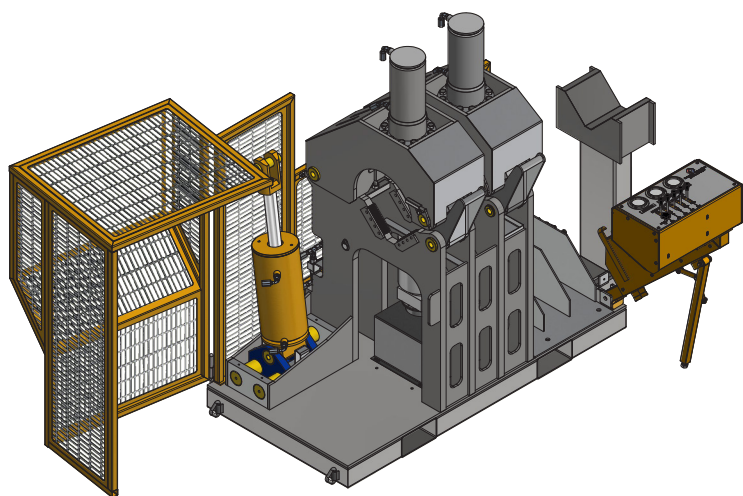

6-12 BREAKOUT BENCH - M2914-62

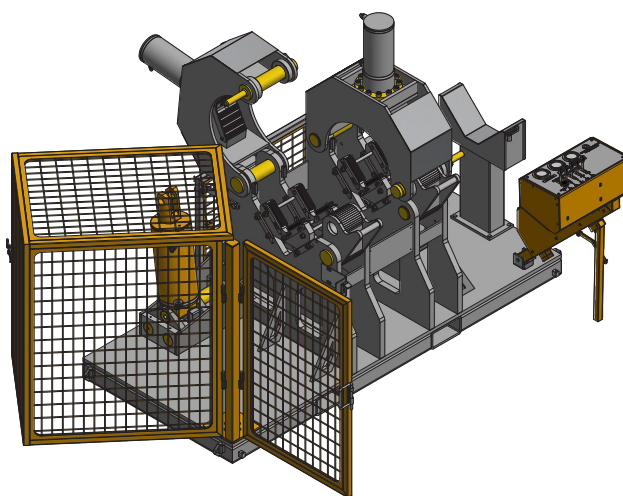

12-18 BREAKOUT BENCH - M2914-62

MODEL	POWER OPTIONS	CLAMP RANGE	CLAMP FORCE	*TORQUE	DIMENSIONS	ORDER CODE
4-8 BREAKOUT BENCH	SINGLE PHASE, THREE PHASE, AIR OVER HYDRAULIC OR DIESEL	*4" TO 8" HAMMERS	70,547 LB.F 32 TONNE	55,000 LB.FT 74,570 Nm	157cm x 80cm x 147cm	M4214-62
6-12 BREAKOUT BENCH	SINGLE PHASE, THREE PHASE, AIR OVER HYDRAULIC OR DIESEL	*6 TO 12" HAMMERS	88,184 LB.F 40 TONNE	100,000 LB.FT 13,5582 Nm	195cm x 100cm x 165 cm	M2916-62
12-18 BREAKOUT BENCH	THREE PHASE, OR DIESEL	12" TO 18" HAMMERS	13,2277 LB.F 60 TONNE	120,000 LB.FT 16,2698 Nm	220cm x 100cm x 165cm	M4104-62

Note: Jaw extensions available to achieve smaller clamping diameters